

APEXRISE

HYDRAULIC JACK PLATE



To the Installer and End User (Owner)

Thank you for choosing a ApexRise Hydraulic Jackplate . These Installation Instructions contain all the information that you and others will require for the safe installation and use of your Jackplate. Throughout this manual, information for the safe installation and operation of the Jackplate will be distinguished in one of the following ways;

WARNING

Hazards or unsafe practices which could result in severe personal injury or death.

Failure to adhere to a warning may lead to loss of vessel control, leading to possible ejection from the vessel causing property damage, personal injury and/or death.

CAUTION

Hazards or unsafe practices which could result in minor injury or product or property damage.

NOTICE

Important information in regards to installation, use and maintenance of the ApexRise Jackplate.

NOTICE

These safety alerts alone cannot eliminate all of the hazards that may be present while on the water. It is recommended that all users of the Jackplate take an accredited 'boating safety course', follow safe boating practices and are made aware of the environment that they will be in.

INDEX

1.0 Safety Information	1
1.1 Before Installation	1
1.2 During Installation.....	1
1.3 Prior to Each Use	2
1.4 During Use	2
1.5 After Use	2
1.6 Maintenance	3
1.7 Corrosion Protection.....	3
1.8 Trailering and Storage	4
1.9 Product maintenance.....	4
2.0 Jackplate Installation	5
2.1 Parts & Tools.....	5
2.2 Mount Jackplate to Boat	7
2.3 Install Relay Wiring Harness	10
2.4 Install Rocker Switch.....	12
2.5 Mount Outboard to Jackplate.....	13
2.6 Clearance Checks	14
3.0 Troubleshooting Guide	15
4.0 Warranty	16
4.1 Statement of 2-Year Limited Warranty.....	16

Introduction

Congratulations on your purchase of a ApexRise Jackplate. You have chosen to install one of the sleekest and most durable engine Jackplates available. Prepare for increased performance, gains in1 fuel economy and the ability to run in shallow water.

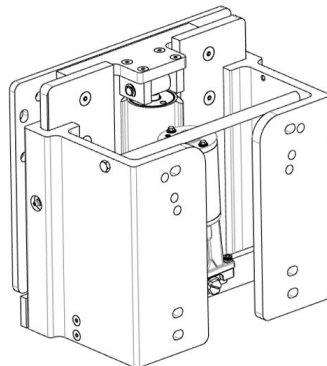

TRANSOM SIDE OF JACKPLATE

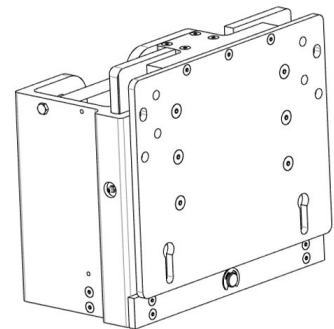

ENGINE SIDE OF JACKPLATE

Figure 1. ApexRise Jackplate.

1.0 SAFETY INFORMATION

WARNING

The safety information provided throughout this publication is intended to inform you of the dangers that may be present during installation and use. It is critical that you read and understand ALL the points noted.

1.1 Before Installation

The safe operation of the ApexRise Jackplate is dependent upon proper installation and maintenance, common sense, safe judgment and the knowledge/expertise of the operator. Every installer/user of the Jackplate should know the following requirements before installing/using the ApexRise Jackplate.

1. Read and understand the Installation and Owner's Manual provided with your motor, steering system, and associated components.
2. Ensure that all components required to complete the installation are on hand.
3. ApexRise components are highly engineered and safety tested to ensure system integrity; DO NOT substitute any component with non-ApexRise components as this may compromise system performance/reliability.
4. Comply with all system ratings/regulations (boat/engine, U.S.C.G.).
- Jackplate MUST be rated for use on the engine(s) installed.

WARNING

For ApexRise Standard Duty Jackplates, the MAXIMUM supported horsepower is 150 HP.

1.2 During Installation

1. Install components as directed in all Installation Instructions.
2. Confirm that there is no interference between the ApexRise Jackplate(s) and the steering cylinder(s), tiebars, steering hoses, outboard engine, outboard engine hoses or any combination of these parts by performing the CLEARANCE CHECKS as detailed in Section 2.6.

1.3 Prior to Every Use

1. Verify immediate response when switch is engaged (UP/DOWN).
2. Inspect the Jackplate(s) for damage, cracks, deformation, wear and binding. Check for loose mounting bolts and/or nuts.
3. Confirm that there is no interference between the ApexRise Jackplate(s) and the steering cylinder(s), tiebars, steering hoses, outboard engine, outboard engine hoses or any combination of these parts by performing the CLEARANCE CHECKS as detailed in Section 2.6.

DO NOT OPERATE BOAT IF ANY COMPONENT IS NOT IN PROPER WORKING CONDITION.

⚠ CAUTION

DO NOT attempt to steer with the engine at full tilt. Damage to the Jackplate(s) and/or steering components could occur.

1.4 During Use

To reduce risk of severe injury or death, always wear a Coast Guard Approved personal flotation device (PFD) and use an engine shut-off cord (lanyard).

⚠ CAUTION

Damage to outboard will occur if proper water pressure is not maintained while the boat is under way. Raising the outboard too high will result in a water pressure drop and overheating of your outboard engine will occur. Proper water pressure must be maintained at all times during operation of the outboard.

⚠ CAUTION

DO NOT attempt to steer with the engine at full tilt. Damage to the Jackplate(s) and/or steering components could occur.

1.5 After Use

1. Rinse off Jackplate(s) thoroughly using fresh, clean water only.
 - Cleaning fluids containing ammonia, acids or any other corrosive ingredients MUST NOT be used for cleaning any part of the Jackplate(s).

1.6 Maintenance

⚠ WARNING

Any work being performed with this system **MUST** be completed by a qualified mechanic with a working knowledge of the system.

After **FIRST** use and every **100 hours** or **6 months** thereafter (whichever comes first).

1. Ensure the transom bolts and engine bolts are torqued to their recommended values.
2. Inspect the Jackplate(s) for damage, cracks, wear and binding. Inspect the Jackplate brackets, guide rods, actuator shaft and actuator shaft seal. Check for leaking components.
3. Inspect electrical cables for damage.

DO NOT OPERATE BOAT IF ANY COMPONENT IS NOT IN PROPER WORKING CONDITION.

1.7 Corrosion Protection

ApexRise Jackplates provide the ability to add an anode to protect your Jackplate in a machined pocket located on the bottom of the lower engine bar shown in figure 2 below.

Anode Pocket

Size: 2.45"×0.98"

Holes: 1/4"-28 UNF (on centers)

Depth: 0.55"

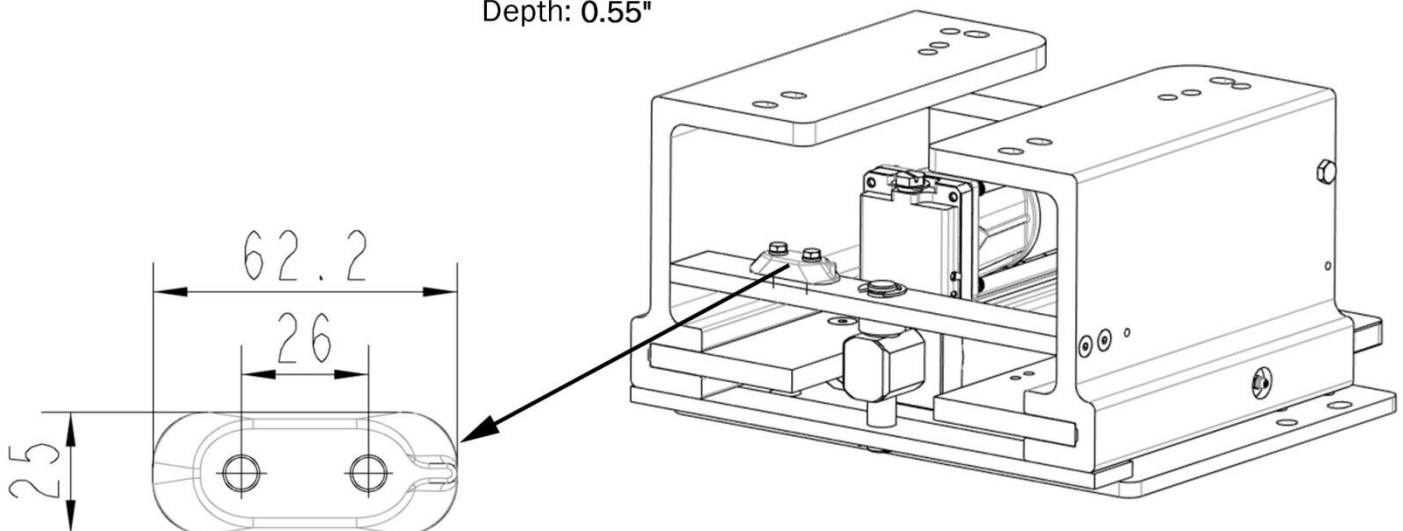

Figure 2. Anode Block

1.8 Trailering and Storage

1. The ApexRise Jackplate will maintain position during operation and short term storage, however it should not be relied on to provide long term support over extended storage or trailering conditions.
2. During storage or trailering, the outboard motor must be positioned in the lowest vertical position and/or at a trim position angle which will not allow interference as defined in Section 2.6.

⚠ WARNING

The Jackplate is a hydraulic system and must not be relied on to maintain position over a long term. Trailer locks and other safety methods must be used.

1.9 Product maintenance

⚠ WARNING

The ApexRise Lubrication Protection System features a grease gun refill function to prevent wear on your jackplate caused by prolonged operation. The lubrication points (grease fittings) are located on both sides of the left and right bracket plates (as shown in Figure 3 below).

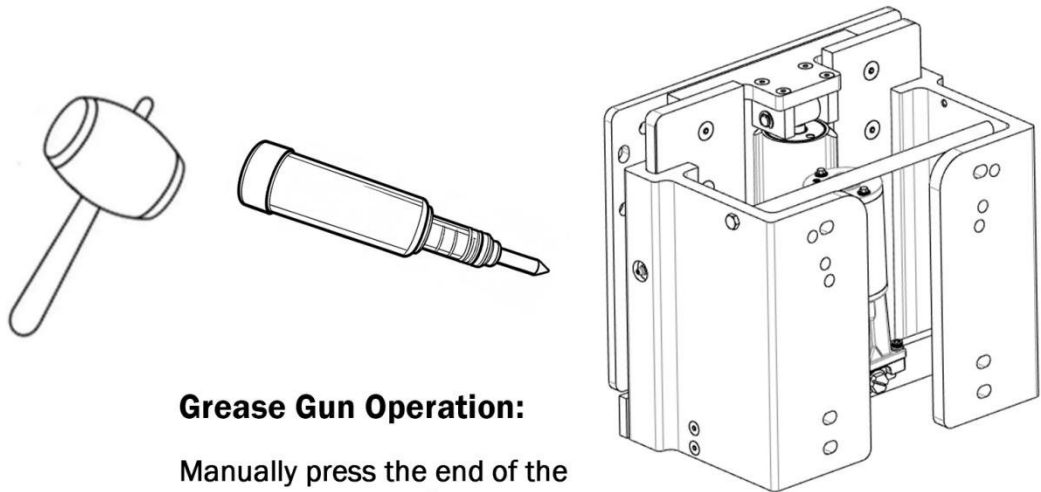

Grease Gun Operation:

Manually press the end of the grease gun to supply grease. If pressing the end is difficult, tap the rear with a rubber mallet.

Figure 3. Grease Gun

2.0 JACKPLATE INSTALLATION

⚠ WARNING

Failure to adhere to these instructions may result in loss of boat control, leading to possible ejection from vessel causing property damage, personal injury and/or death.

Before proceeding with the installation, read these instructions thoroughly. ApexRise cannot accept responsibility for installations where instructions have not been followed, where substitute parts have been used, or where modifications have been made to our products.

2.1 Parts & Tools

If you have questions or feel that you can not properly install this hydraulic Jackplate, **STOP** operation immediately and contact the relevant personnel.

INCLUDED PARTS

- [1] Vertical Bracket
- [2] Relay Wiring Harness with Spade Terminals
- [3] Rocker Switch
- [4] 4 Sets of Mounting Bolts
- [5] Grease Gun
- [6] Drain Cover Wrench

OTHER TOOLS, EQUIPMENT

- Floor crane/Overhead hoist
- Torque wrench
- Outboard engine lifting eye
- Mounting screws for relays
- 16 AWG wire and inline 10A fuse (For switch power line installation.)
- Engine mounting hardware (As supplied/recommended by engine manufacturer.)

⚠ WARNING

For outboard engines with a power output exceeding 60 horsepower, it is recommended to use 6 sets of mounting bolts.

OTHER CONNECTION HARDWARE (NOT SUPPLIED)

- Marine sealant suitable for below waterline use.

Jackplate to Transom Connection:

- Stainless steel outboard engine bolts supplied by or approved by the engine manufacturer.
- Stainless steel washers supplied by or approved by the engine manufacturer.
- Brass nuts with nylon locking elements supplied by or approved by the engine manufacturer.

NOTICE

For vessels at 10" or more offshore, or outboards over 60 HP, use 6 sets of mounting hardware to fasten the top plate to the transom. See warning instructions for details.

⚠ WARNING

In the absence of engine supplied hardware, bolts must conform to ASTM F593C and have a minimum yield strength of 55,000 psi.

Outboard Engine to Jackplate Connection:

- Stainless steel outboard engine bolts supplied by or approved by the engine manufacturer.
- Stainless steel washers supplied by or approved by the engine manufacturer.
- Brass nuts with nylon locking elements supplied by or approved by the engine manufacturer.

⚠ WARNING

If the outboard engine manufacturer has supplied installation instructions, those guidelines MUST be followed during installation.

NOTICE

The use of a transom stiffener for the top bolts on the transom side of the jackplate-to-transom connection is recommended.

⚠ WARNING

Check the outboard engine manufacturer's instructions carefully for specifications regarding connection hardware. Ensure the outboard engine manufacturer's requirements are followed.

The following parts are included with your ApexRise Jackplate product. If any of these components are missing, contact your dealer or ApexRise.

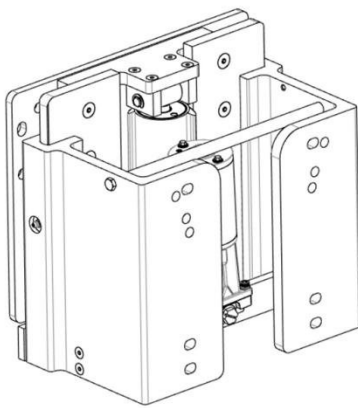

[1] Vertical Bracket



[2] Relay Wiring Harness
with Spade Terminals

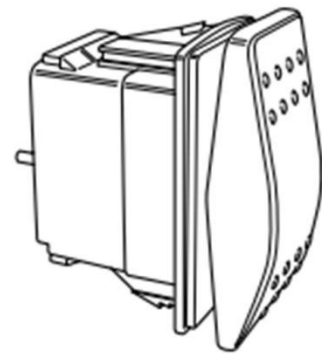

[3] Rocker Switch

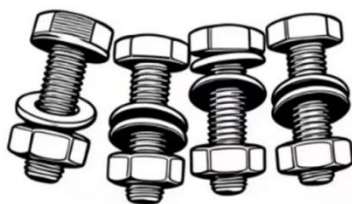

[4] 4 Sets of
Mounting Bolts



[5] Grease Gun

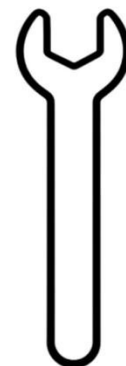

[6] Drain Cover
Wrench

Figure 4. Included parts.

2.2 Mount Jackplate to Boat

NOTICE

The following procedure outlines the process of first mounting the Jackplate on the boat, followed by installing the engine to the Jackplate. If desired, the Jackplate can first be installed on the engine, followed by installation on the boat. The order of installation may be altered but individual steps must be followed and all warnings and cautions must be followed.

- 1. PRIOR** to mounting the Jackplate to the transom, insert the engine bolts into the engine side of the Jackplate. Use the 1/2" SAE washers (not supplied).
- Using connection hardware supplied by or approved by the outboard engine manufacturer, mount the Jackplate to the transom.

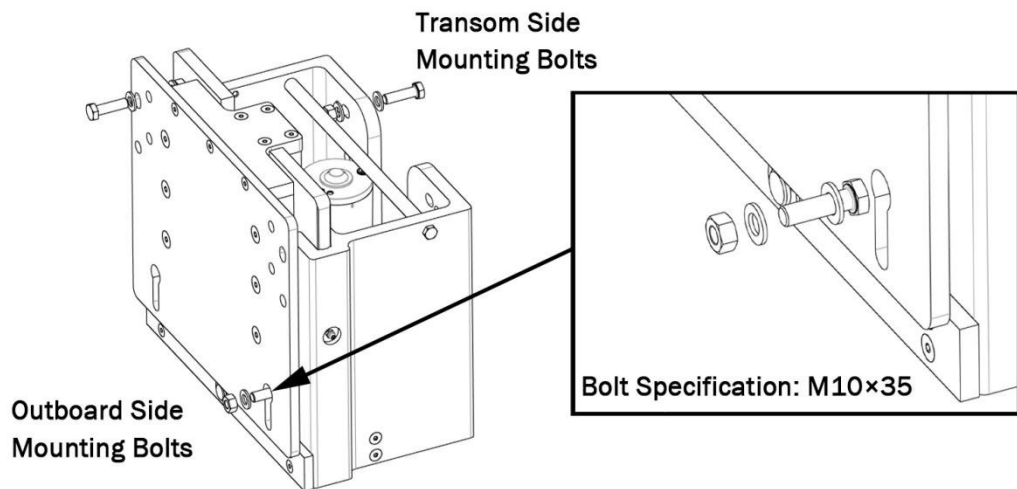

For each engine, increase the number of bolts as recommended by the manufacturer. See the notice for details.

Figure 5. Engine bolt insertion.

NOTICE

Temporary connection of the harness will allow you to actuate the Jackplate. This may assist in the installation of the engine bolts. See Section 2.3.

NOTICE

Six bolts **MUST** be used for mounting engine to Jackplate if recommended by engine manufacturer.

3. If the Jackplate setback is 10 inches or more, or if the outboard engine output is 60 horsepower or more, it is recommended to use 6 mounting bolts at the transom connection. Additional mounting bolts should be used in the upper holes on the Jackplate hole pattern. See figure 8.
4. Seal all holes in the transom with an appropriate marine sealant.

⚠ WARNING

Use only M10×35 GB bolts with engine mountings to ensure proper clearance and bolt preload.

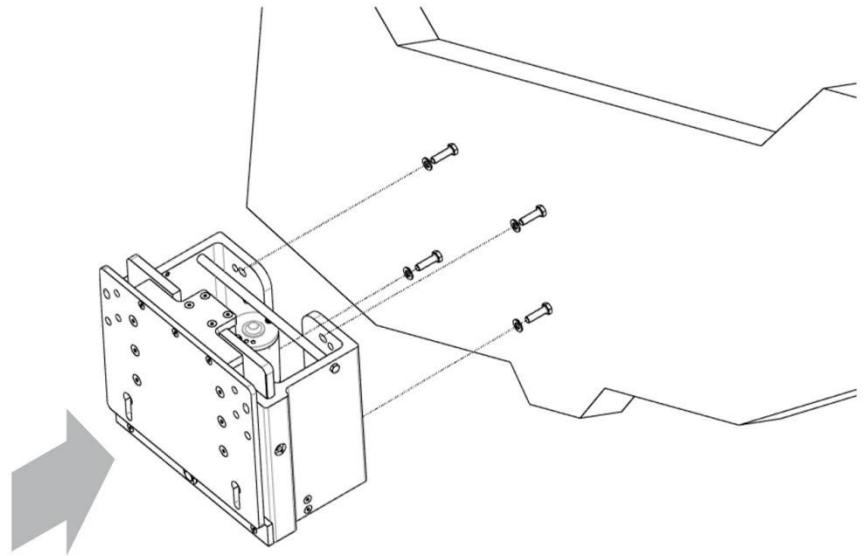

For outboard engines over 60 HP, 6 sets of mounting hardware are recommended to fasten the top plate to the transom.

Figure 6. Jackplate to transom connection.

NOTICE

At the lowest position, the Jackplate provides a 2-1/2" lift offset between the transom and the engine.

⚠ WARNING

CRUSH HAZARD. Moving Jackplate parts can crush. Keep all body parts free and clear when actuating the Jackplate.

⚠ WARNING

Use of non-approved bolts and washers may lead to separation of engine from boat.

⚠ WARNING

Follow the outboard engine manufacturer's recommendations for tightening torque.

⚠ WARNING

The use of 6 mounting bolts is recommended for installations of 10" or 12" setbacks or for outboard engines with output greater than 60 horsepower.

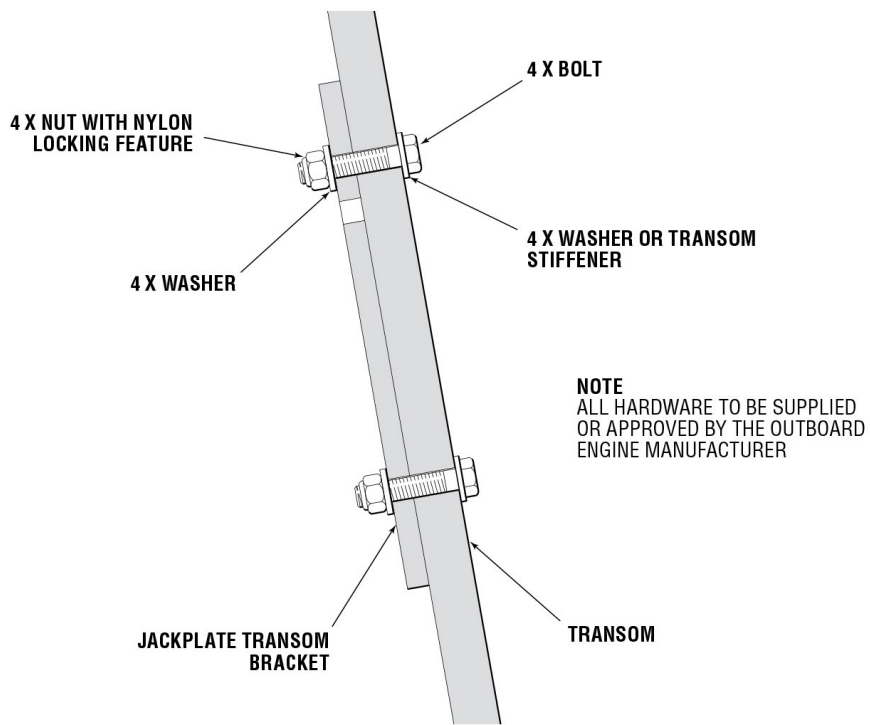

Figure 7. Jackplate to transom connection.

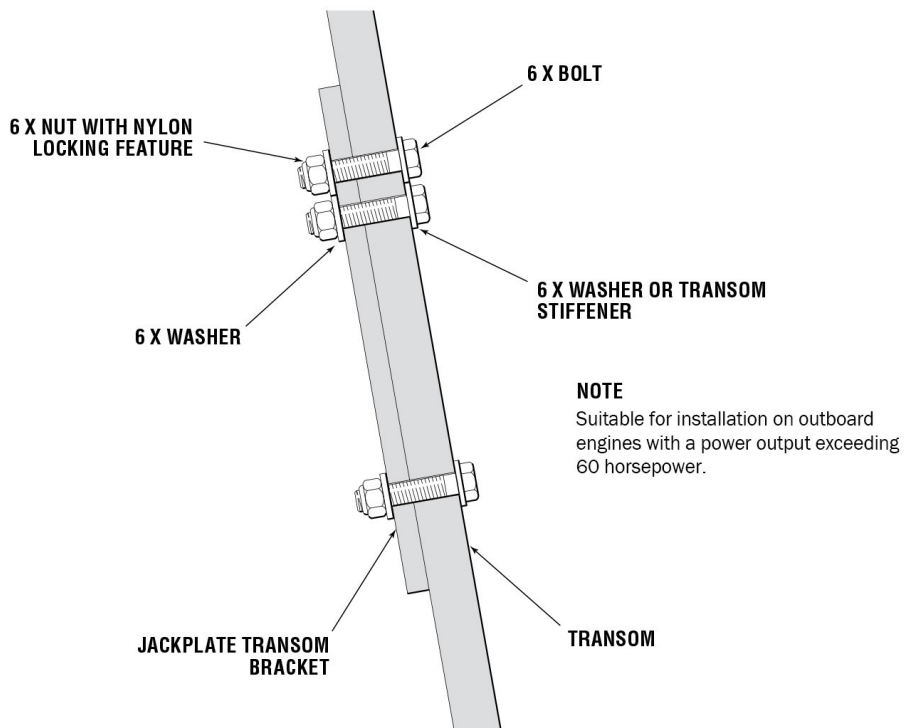

Figure 8. Jackplate to transom connection for 10" or 12" setbacks, or for outboards greater than 250 HP.

6. Using a torque wrench, tighten the nuts to the manufacturer's recommended torque.

Record the torque values here for future reference.

_____ ft-lbs. _____ Nm.

2.3 Install Relay Wiring Harness

⚠ CAUTION

Before operating the Jackplate, check mounting bolt clearances and ensure that shift and throttle cables, electrical lines, tiebars, fuel hoses, and all other equipment are clear of the Jackplate so they will not be pinched or kinked when the unit is moved up and down.

1. Find a dry and accessible place to mount the Relay Wiring Harness. Use the mounting holes on the relay brackets to secure the harness to the boat.

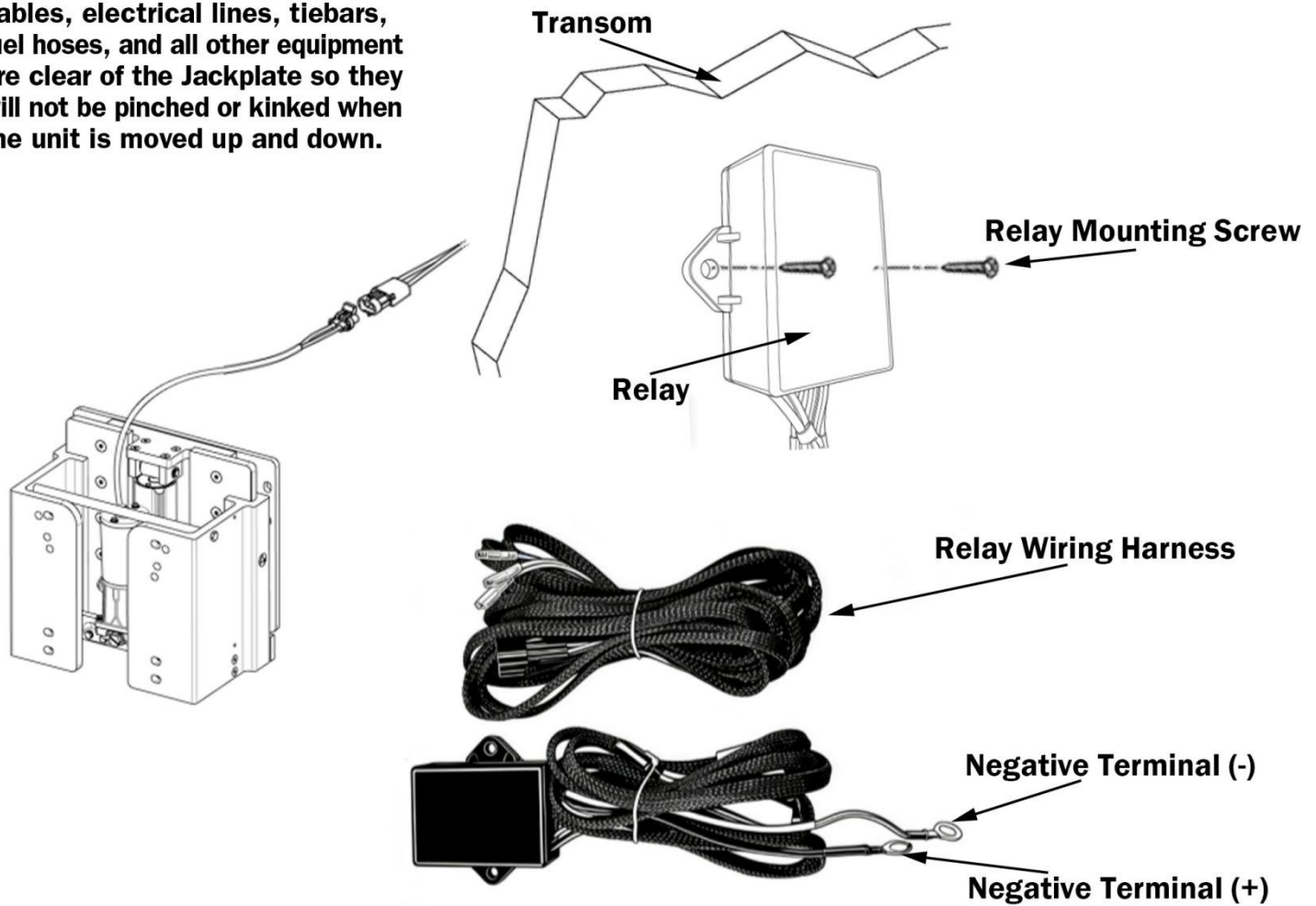

Figure 9. Relay Wiring Harness installation and connections.

⚠ CAUTION

Ensure the harness has proper strain relief and is routed to avoid damage/pinching/chafing.

2. Attach the ring terminal from the circuit breaker to a 12V positive (+) post on the outboard engine battery.
3. Attach the black ring terminal to a negative (-) post on the same battery as step 2.

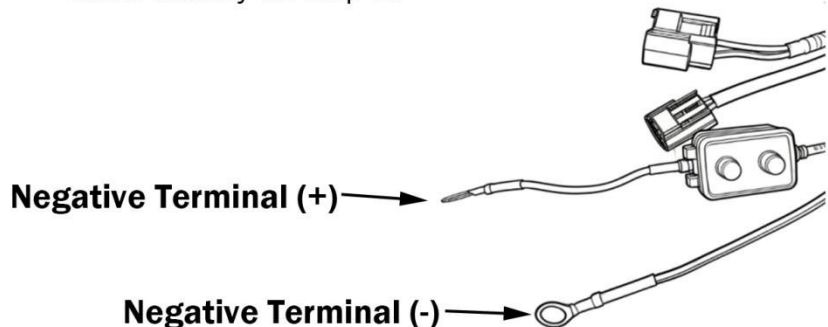

Figure 10. Battery connections.

Main Wiring Diagram

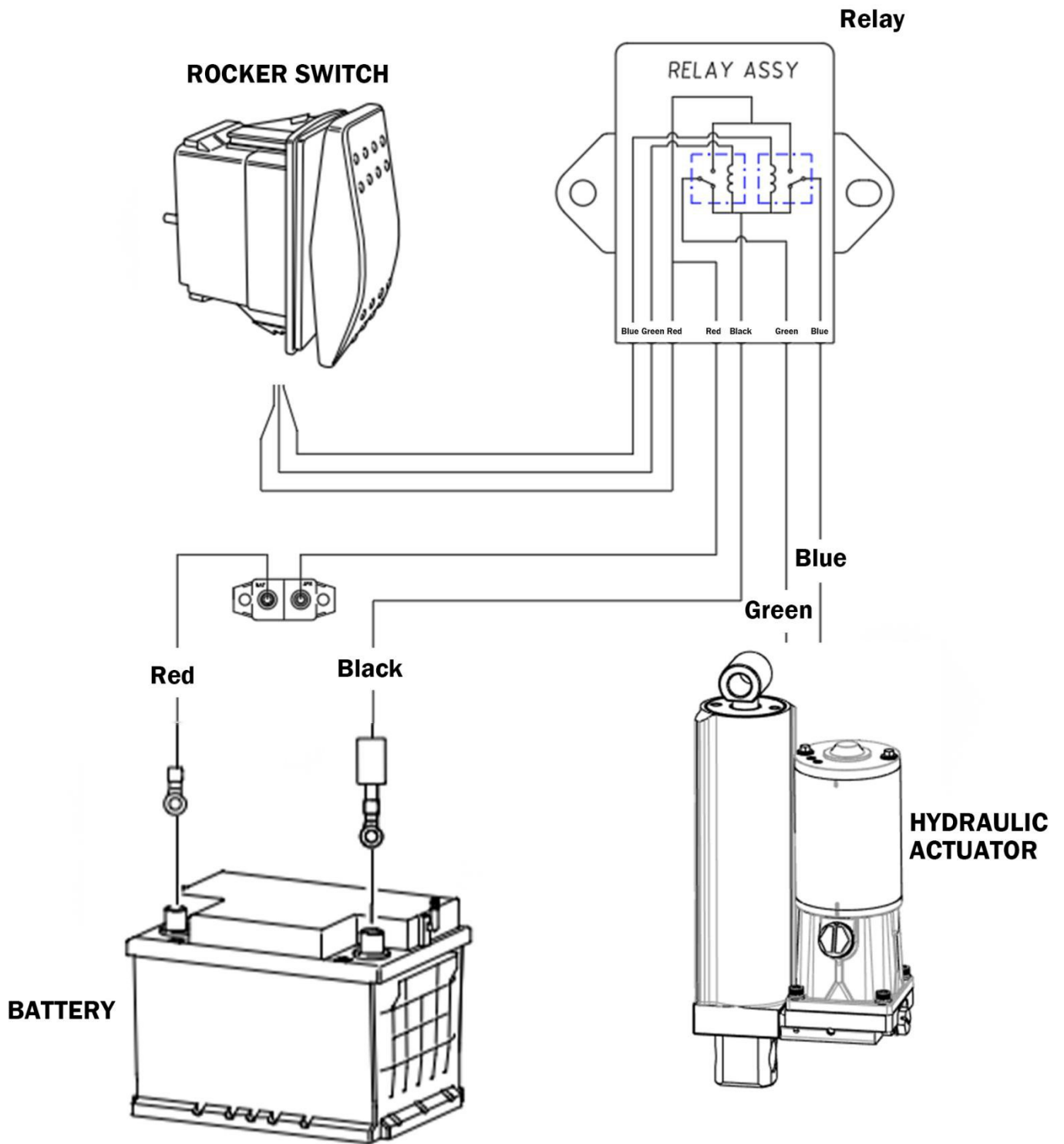

Figure 11. Main Wiring diagram.

2.4 Install Rocker Switch

NOTICE

Position the rocker switch so that it is within easy reach of the operator.

NOTICE

The switch leads from the relay wiring harness may not be long enough to reach the rocker switch position on the dashboard or console. In this case the leads will need to be extended.

⚠ CAUTION

Any additional wire spliced to the Relay Wiring Harness must be marine grade and meet SAE J1128.

⚠ CAUTION

Any wire from a 12V(+) source must be protected with an appropriate fuse or circuit breaker.

NOTICE

If the Jackplate actuation direction is inconsistent with the rocker switch direction, swap the positions of the GREEN/WHITE and BLUE/WHITE wires on the switch spades.

⚠ CAUTION

Ensure the harness has proper strain relief and is routed to avoid damage/pinching/chafing.

1. Cut an appropriate rectangular opening in the dashboard or console panel where the rocker switch is to be mounted.

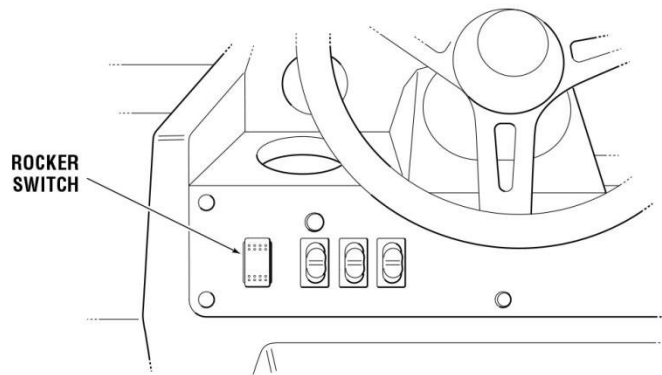

Figure 12. Rocker Switch on dash.

2. Route the switch leads from the relay wiring harness to the hole in the dashboard.
3. Terminate the end of the switch leads with the supplied spade terminals.
4. Route a fused (10A) 16AWG wire from a 12V (+) position on the fuse panel or from the battery and terminate with a supplied spade terminal.
5. Attach the wires to the spades on the back of the rocker switch. The wire from the 12V (+) source should attach to the CENTER spade on the rocker switch.
6. Do not seat the switch into the dash until after the rest of the installation is complete and you have confirmed the Jackplate direction is consistent with the switch direction.

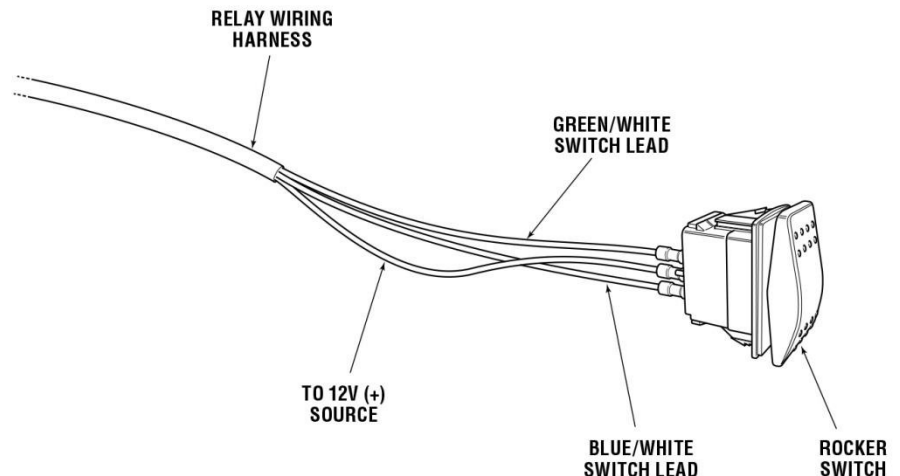

Figure 13. Rocker Switch connections.

2.5 Mount Outboard to Jackplate

NOTICE

Jackplate position can be extended or retracted during installation to improve tool access to mounting hardware.

⚠ WARNING

CRUSH HAZARD. Moving Jackplate parts can crush. Keep all body parts free and clear when actuating the Jackplate.

⚠ WARNING

All engine mounting hardware must conform to the standards specified in Section 2.1.

⚠ WARNING

For ApexRise Standard Duty Jackplates the **MAXIMUM** supported horsepower is 150 HP.

For ApexRise Xtreme Jackplates the **MAXIMUM** supported horsepower is 150 HP.

1. Using an appropriate hoist and lifting eye, lift the outboard into place.
2. Select the hole set on your outboard engine that will best suit the boat and application.
3. Move the engine forward on the hoist while feeding the bolts into the mounting holes.
4. Install the washers and nuts and tighten. Ensure approved bolts, nuts and washers are used. See Section 2.1.
5. Using a torque wrench, tighten to 40 Nm (29.5 ft-lbs) or to engine manufacturer's recommended value for installation on Jackplate.

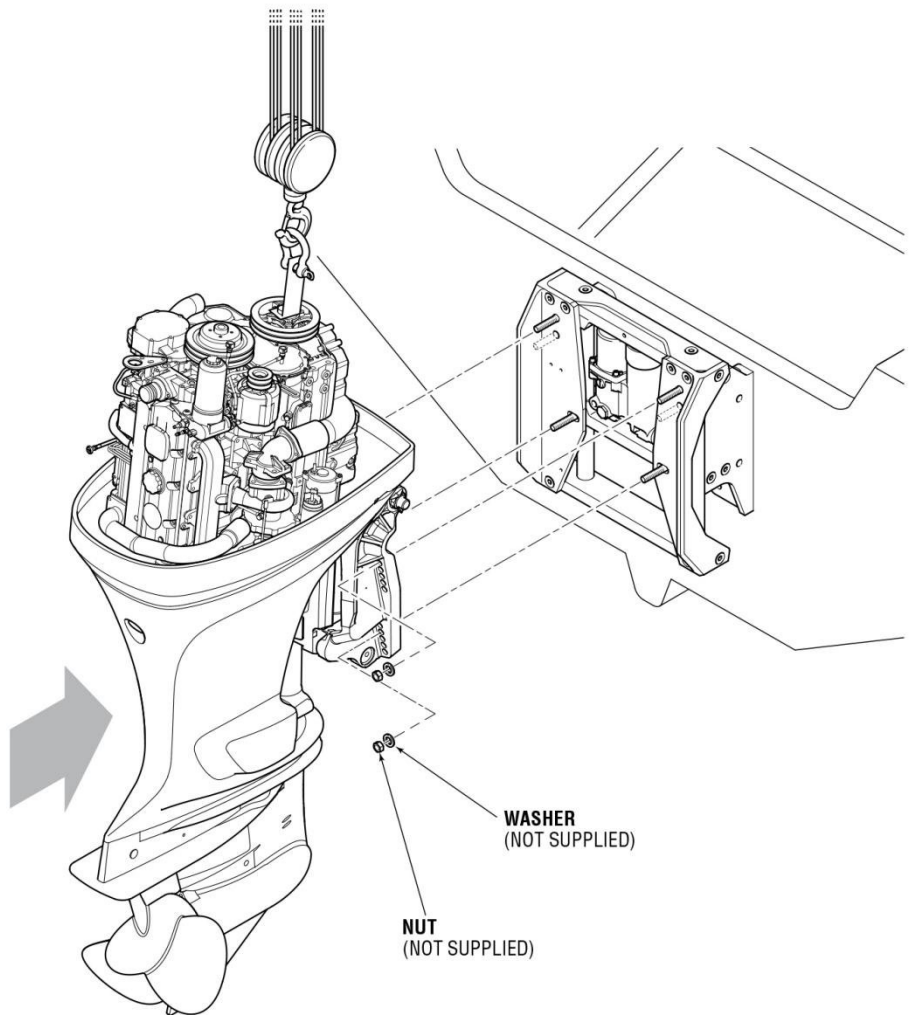

Figure 14. Outboard installation.

⚠ CAUTION

Perform the Clearance Checks prior to water testing. See Section 2.6.

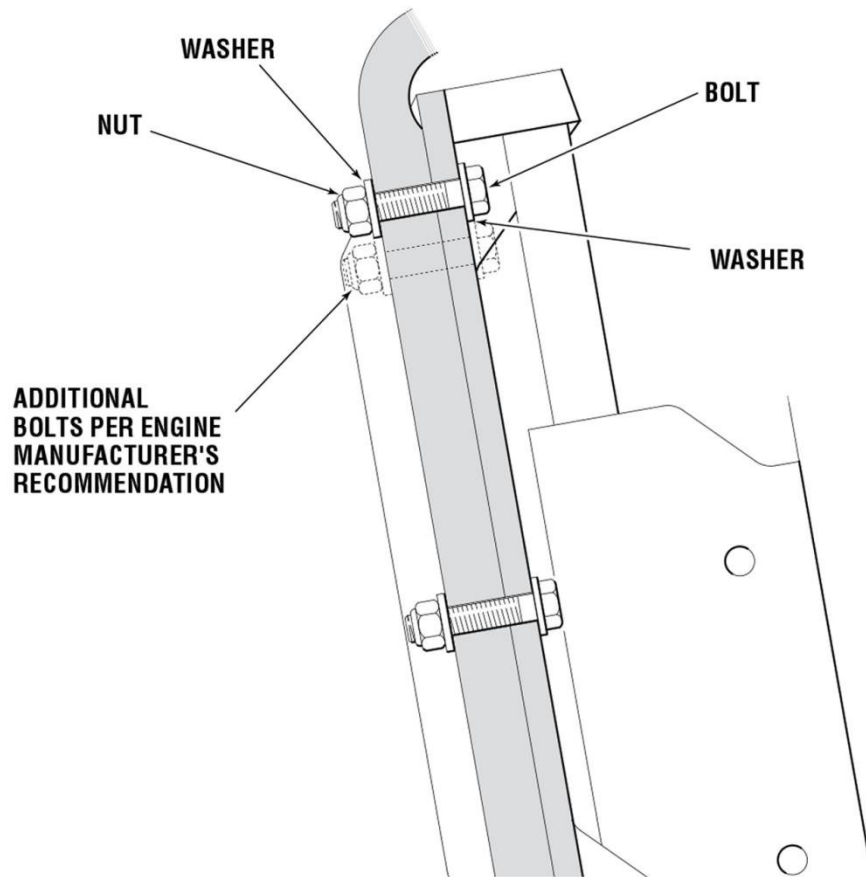

Figure 15. Outboard Engine to Jackplate connection.

2.6 Clearance Checks

⚠ WARNING

Jackplate clearance checks MUST be completed after installation and before use. Failure to adhere to this warning may result in the loss of vessel control, leading to possible ejection from vessel causing property damage, personal injury and/or death.

1. Starting with the Jackplate at its lowest position, verify full steering travel through the entire trim range.
2. At the full down position, with the steering at center, CAREFULLY tilt the engine and verify that no interference occurs as the outboard engine is tilted. Check for interference between the SeaStar Jackplate and the steering cylinder(s), tiebars, steering hoses, outboard engine, engine hoses or any other components.
3. If any interference exists, action must be taken to do one of the following:
 - a. Add a tilt limiter device to the outboard engine and ensure it is set to prevent the engine from reaching a position where interference is possible.
 - b. Move the engine up to a higher set of mounting bolt holes.

⚠ WARNING

Interference with any object MUST be corrected prior to use.

3.0 TROUBLESHOOTING GUIDE

FAULT	CAUSE	SOLUTION
1. Unit leaks down over short period of time.	<ul style="list-style-type: none">• Internal fluid bypass.	<ul style="list-style-type: none">• Actuate Jackplate several times in extend and retract direction.
2. Unit fails to reach limit of extension or retraction or binds at an angle near limit of travel.	<ul style="list-style-type: none">• Mechanical interference with other components.	<ul style="list-style-type: none">• Check for interference between moving components including: mounting fasteners, steering system, loose parts, tools, etc.
3. Unit operates slowly or erratically during extend or retract.	<ul style="list-style-type: none">• Low supply voltage.	<ul style="list-style-type: none">• Check supply voltage. Voltage at actuator leads must be between 10.5 and 14 V.
4. Does not run in either direction.	<ul style="list-style-type: none">• Dead or low battery.• Tripped circuit breaker. • Tripped motor thermal breaker.• Faulty electrical connection. • Faulty relay. • Mechanical interference with other components.	<ul style="list-style-type: none">• Check supply voltage. Voltage at actuator leads must be between 10.5 and 14 V.• Check continuity across circuit breaker near positive battery terminal. If the breaker is manually-resettable, press reset button. If the breaker does not have a button, it will automatically reset after it cools down.• Allow motor to cool down to reset automatically.• Check for continuity in all harness wires and connections in harness, including: battery connection, circuit breaker, harness wires, switch wires, switch wire fuse. Check function of switch for continuity. Replace faulty connections if necessary.• Check for correct function of relays on harness. On activation of the switch in either direction, there should be an audible click in the relay and continuity across relay lines when switching. Replace faulty relay if necessary.• Check for interference between moving components including: mounting fasteners, steering system, loose parts, tools, etc.

4.0 WARRANTY

4.1 Statement of 2-Year Limited Warranty

The APEXRISE warrants its products to be free from defects in materials and workmanship for a period of two years from the date of original retail purchase, We will provide replacement product without charge for any APEXRISE product covered by this warranty, which is returned (freight prepaid) within the warranty period to the dealer from whom such products were purchased, or to us at the appropriate address. In any such case, SAPEXRISE products found to be defective and covered by this warranty will be replaced or repaired at APEXRISE option.

APEXRISE sole responsibility under this warranty is limited to the repair or replacement of product which is, in APEXRISE opinion, defective.

APEXRISE is not responsible for charges connected with the removal of such product or re-installation of replacement or repaired parts.

We will have no obligations under this warranty for any product which:

- has been improperly installed;
- has been used in an installation other than as recommended in our installation or operation instructions or specifications;
- has failed or has been damaged due to an accident or abnormal operation including racing, misuse or alterations outside our factory;
- has been repaired or modified by entities other than APEXRISE ;
- has been used on an engine/boat combination where the engine horsepower exceeds the rating established by the boat manufacturer;
- has been used with other product(s) which, in APEXRISE opinion, are incompatible with the APEXRISE product.